



ADVANCING CLEAN AIR SOLUTIONS **TOGETHER**

Total Product Brochure
Filter Cleaning Solutions



GOYENMECAIR.PENTAIR.COM

YOUR PARTNER FOR OPTIMIZED FILTER CLEANING SOLUTIONS



Pentair, with its global brands Goyen and Mecair, is the market leader in reliable dust collector components. We develop and produce all constituent parts to the highest quality and safety standards, from pulse jet valves and pulse cleaning controllers to certified and custom-engineered header tank solutions.

Since 1935, we have provided engineering expertise and partnerships to several of the world's leading dust collector manufacturers. Our diaphragm valves simply deliver the most powerful air pulses. These valves are designed for dust collectors with reverse pulse-jet filter cleaning systems, including all bag filters, ceramic filters and sintered metal fiber filters.

The rugged design and construction of our valves, and the resulting reliability, has led to their use in high-performance systems around the world. Dust collectors may be used to control the dispersion of noxious substances, improve indoor air quality in workplaces, or prevent harmful emissions. The advanced Pentair technology, backed up by more than 80 years of practical industrial experience and application know-how, has made our components the preferred choice for demanding industries and processes, including:

- ◆ cement production
- ◆ mining applications
- ◆ silo and conveyor systems, bulk goods handling
- ◆ general industrial dust collection
- ◆ improving indoor workplace air quality
- ◆ preventing harmful emissions
- ◆ protecting gas turbines in the power industry

We have created the most efficient filter cleaning controls available today, from simple four-valve timers all the way to networked systems that operate a thousand reverse pulse jet valves at -40° . We offer practical and effective solutions for applications ranging from silo venting to massive gas turbine intake filter systems. A broad range of certifications underpins our product range. Let us help you maximize the life of filter media and minimize the cost of achieving the best possible cleaning cycle.

YOUR ONE STOP SUPPLIER

ADVANCED PULSE JET VALVES



Our pulse jet valves are ready for use in any dust collector design and have the most powerful air pulse to solve your cartridge filter or baghouse cleaning challenges. Various connections are available such as threaded, dresser nut, manifold mounted or flanged ports.

ENCLOSURE FOR (NON-)HAZARDOUS LOCATIONS



Pentair's enclosures for hazardous locations offer reliable protection for the pilot valves of your filter cleaning system in high-risk environments. The Goyen and Mecair enclosures are dust and gas explosion proof and are available with UL, CSA and ATEX approvals.

HEADER TANK SYSTEMS



Pentair offers complete and fully certified header tank systems specifically engineered for dust collector filter cleaning. We introduced the Full Immersion system with optimized flow rate for the best cleaning results in the market.

PNEUMATIC AIR CANNON



Our Air Cannon is designed to cost-efficiently dislodge dust from hopper walls and silo bottoms with powerful air bursts. Thanks to the special diaphragm valve with an extremely high flow rate and an air accumulator it is more efficient than 'fluidification' and 'vibration' systems.

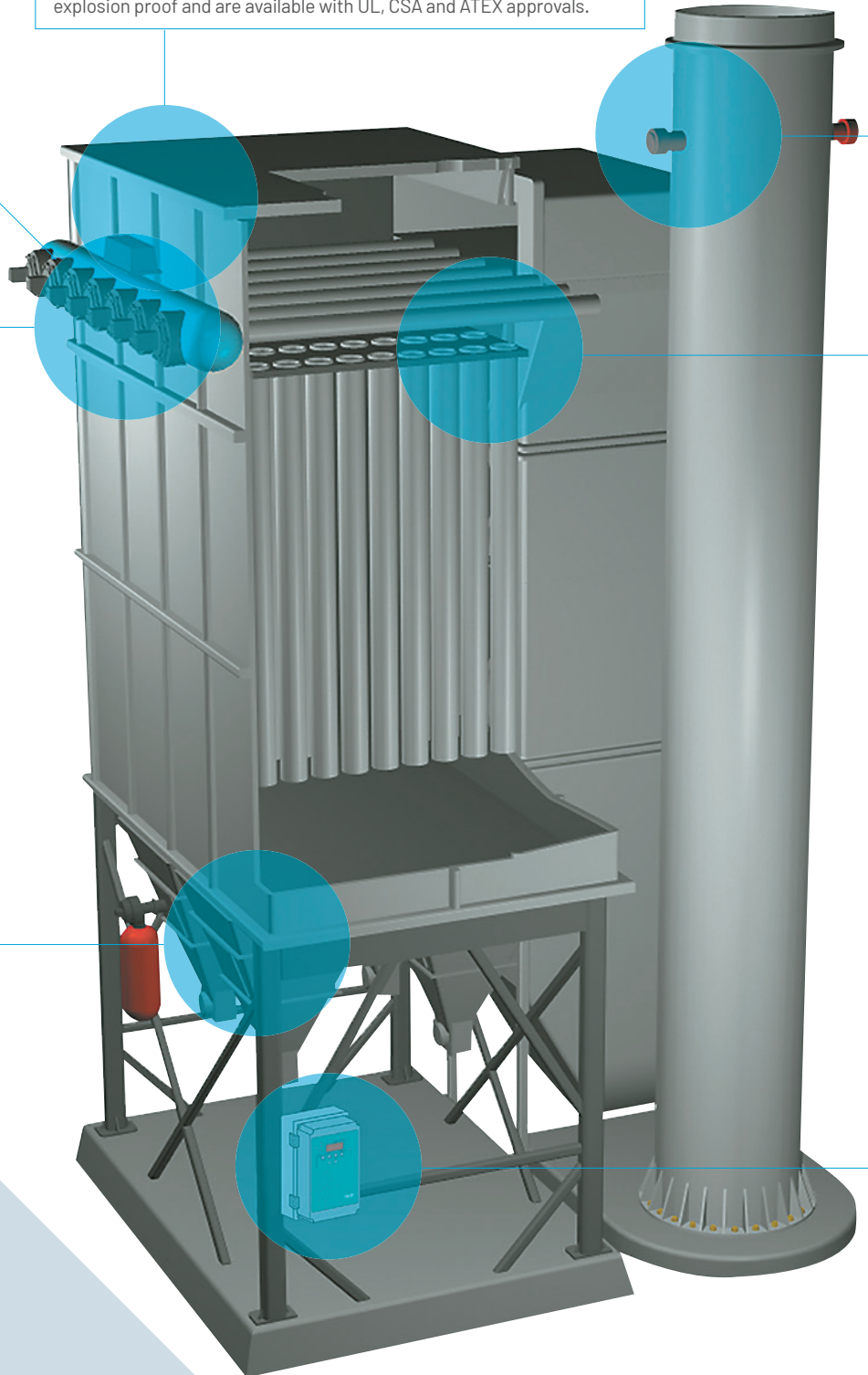

MAIN BENEFITS

PARTICULATE EMISSION MONITORING



Particles in emission outlet streams of various manufacturing processes need to be measured to meet health, safety and environmental regulations. Our range of monitors use advanced ISE and Triboelectric technology for emissions monitoring and broken bag detection purposes.



◆ Optimize your filter cleaning design with GOCO



◆ Unique Certified Header Tank Solutions



◆ Most Powerful Pulse Jet Valves for superior filter cleaning results

BLOWTUBE NOZZLES



The Goyen and Mecair blowtube nozzles and cartridge cleaning cones ensure effective filter cleaning with reverse pulse jet air. The product ranges offer extensive connectivity options and high efficiency through balancing air flow and minimizing pressure drops through blowtube holes.



◆ Lower energy consumption



◆ Reduced need for compressed air



◆ Longer filter life, lower dust collector OPEX

FILTER CLEANING CONTROLLER

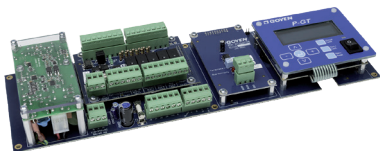

Several decades of filter cleaning expertise have resulted in the most effective filter cleaning controls available today. Our range of controllers can be used for continuous control up to on-demand mode and from standalone systems to systems up to 4800 outputs.



◆ Safest Pilot Enclosures (UL, CSA & ATEX)



◆ Vast portfolio of original spare parts such as membrane kits

ADVANCED DIAGNOSTIC & SYSTEM MODELLING SERVICE: GOCO

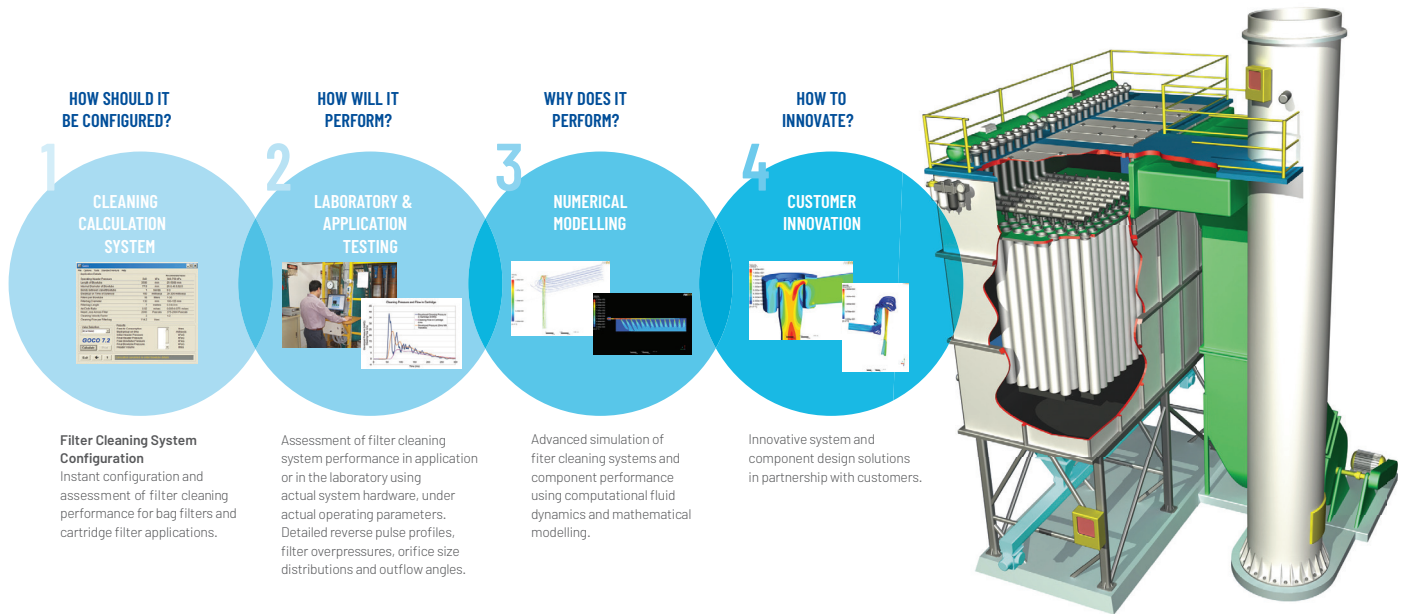

FOR A CUSTOM DESIGNED SYSTEM OR FOR MORE INFORMATION CONTACT YOUR LOCAL PENTAIR FILTER CLEANING EXPERT.

ELIMINATE RISK

- ◆ Better cope with changing dust loads
- ◆ Reduce risk of system failure

MINIMIZE OPERATING COSTS

- ◆ Reduce compressor demand
- ◆ Reduce pulse noise
- ◆ Improve filter cleaning process

INCREASE FILTER LIFE

- ◆ Improve scrubbing efficiency
- ◆ Reduce pulse rate
- ◆ Reduce maintenance frequency



Goyen Controls Pty Limited
268 Milperra Road
Milperra NSW 2214
Australia
www.goyenmecair.pentair.com

Mecair srl
Via Bertacciola 50
20813 Bovisio Masciago (MB)
Italy
www.goyenmecair.pentair.com

Note: The information and data contained in this document are based on our general experience and are believed to be correct. They are given in good faith and are intended to provide a guideline for the selection and use of our products. Since the conditions under which our products may be used are beyond our control, this information does not imply any guarantee of final product performance and we cannot accept any liability with respect to the use of our products. The quality of our products is guaranteed under our conditions of sale. Existing industrial property rights must be observed.

BROC PENTAIR GOYEN MECAIR ADVANCED CLEAN AIR SOLUTIONS TOGETHER 3218 © 2018 Pentair. All Rights Reserved.