

SÜDMO

CONSTANT PRESSURE VALVES

RELIABLE, REPEATABLE BACK PRESSURE

CHALLENGE

Maintaining a reliable, repeatable back pressure on process lines with varying flow rates and viscosities is a challenge in today's processing facilities.

Traditional back pressure valves are costly and hard to maintain. They use laminated diaphragms, which are prone to cyclic fatigue, pressure shocks and chemical attack from aggressive media and cleaning chemicals. These diaphragms are expensive to replace, both in materials costs and plant downtime.

SOLUTION

Pentair Südmö designed a balanced, 100 percent stainless steel valve that eliminates the issues related to diaphragm fatigue, while providing excellent control of back pressure with varying flow and viscosity characteristics. Pentair Südmö's lip seal arrangement provides easy maintenance compared to valves that use diaphragms.

What sets our Constant Pressure Valve apart from the competition is that it is available in more sizes – from 1 to 4 inches – and has a stainless steel regulating cone instead of a diaphragm. The simple design is a variation on our proven single seat valve range. It can be retrofitted into any existing system, regardless of manufacturer.

With no automation required, the self-regulating air supply unit is set at installation and the need for adjustment is eliminated.



BENEFITS

- One-piece balanced solid stainless steel plug
- Standard FDA elastomers for dairy applications
- Dual air supply for actuation during CIP to ensure 100% cleaning
- No automation feedback loops required to ensure accurate constant back pressure
- "Set and forget" self-regulating air supply unit
- Low cost seal kit eliminates expensive diaphragm

APPLICATIONS

- Separators in liquid milk and cheese facilities
- Milk standardization systems
- Utility header returns
- Filling operations

SÜDMO

CONSTANT PRESSURE VALVES

RELIABLE, REPEATABLE BACK PRESSURE

TECHNICAL SPECIFICATIONS

Materials

Product wetted: 1.4404 (AISI 316 L)

Parts not product wetted:

1.4301 (AISI 304), 1.4307 (AISI 304 L)

Other materials on request

Sealing materials (FDA)

EPDM / PEEK

Other sealing materials on request

Continuous operating temperature

EPDM 130° C/265°F *

Sterilization temperature

EPDM 150°C/302°F* (approx. 20 min.)

Operating pressure

10 bar (145 psi)

Higher pressures on request

Adjustment pressure'

On request

Product wetted surfaces

$Ra \leq 0,8 \mu m$

Connections

Standard welding ends for pipes acc. to

DIN 11850 series 2 (DIN 11866 series A),

OD-tube (ASTM A270, DIN 11866 series C,

ASME BPE-2009)

Other tube diameters (e.g. DIN EN ISO 1127)

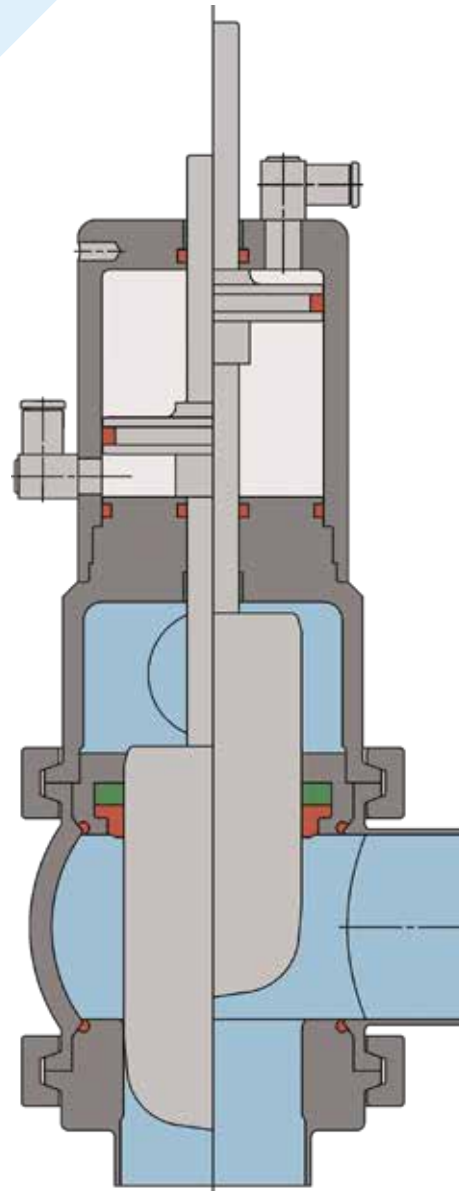

PENTAIR SÜDMO GMBH

INDUSTRIESTRASSE 7, 73469 RIESBÜRG, GERMANY INFO.SUEDMO@PENTAIR.COM WWW.FOODANDBEVERAGE.PENTAIR.COM

All Pentair trademarks and logos are owned by Pentair. All other brand or product names are trademarks or registered marks of their respective owners. Because we are continuously improving our products and services, Pentair reserves the right to change specifications without prior notice.

Pentair is an equal opportunity employer.

constant-pressure-valve-2111-en © 2021 All Rights Reserved.