

**PENTAIR  
HYGIENIC PROCESS VALVES  
(FORMERLY KEYSTONE)**

# F269B+ INSTALLATION AND OPERATING INSTRUCTIONS

# PENTAIR HYGIENIC PROCESS VALVES (Formerly Keystone)

# BALANCED DOUBLE SEAL VALVES

## F269B+ (Reversible)

**Installation and Operating Instructions - Repair and Maintenance Instructions. Before installation and operating, these instructions need to be read and understood.**

### TRANSPORT AND STORAGE

The valve has been fully wrapped in plastic. This prevents dust and dirt entering the valve interior. Re-wrap the interior components when the valve is unpacked for installation of the body into the pipe work, to avoid unwanted contamination and damage.

### INSTALLATION

#### Orientation of valve

When installing valves into piping systems they must be orientated so the media is free draining. Free draining refers to the media, e.g. liquid, freely draining under gravity when in discharge mode. This valve is only suitable for vertical orientation. For proper operation of the leak detection, the valve should be oriented vertically, with the top of the air cylinder facing upward.

#### Installation into pipework

The valve can be welded in the pipe work directly.

Important: To avoid seal damage remove the valve internal parts, together with all O-rings and seals, before welding. Use qualified welding personal to the end users specifications if required.

#### Operating space

For switching of the valve a free space is required above the actuator of at least 50 mm. If a control head is fitted, the following minimum distances above is required to remove the control head/ cap:

F783E: 60mm

F784: 110mm

#### Mounting space

To allow easy valve assembly and disassembly, a free space is required above the actuator of at least 4 x the largest pipe diameter.pipe diameter.

### SAFETY PRECAUTIONS



#### Caution!

Before attempting to remove the valve from service, ensure all pipelines connected to the valve are depressurised and evacuated of all compressed air, liquids or process media. LOCKOUT procedures must be in place to prevent lines becoming charged with process or cleaning fluids during maintenance.

#### Caution!

Keep fingers clear of moving parts at all times when operating the actuator. When handling the actuator, never place any part of the body between the plug sealing faces and the valve seats while the actuator is charged with air.

#### Caution!

The F272S actuators are seal welded and contain a spring under compression. DO NOT attempt to dismantle this sealed unit, as the spring could cause serious harm.

#### Caution!

Before disassembly of spring-to-close valves, compressed air must be used to move the valve to the open position. Failure to do this will result in the actuator/plug assembly leaping out of the valve body when the upper clamp is removed, possibly causing injury.

# PENTAIR DOUBLE SEAL VALVES

## F269B+ INSTALLATION AND OPERATING INSTRUCTIONS

### REPAIR AND MAINTENANCE INSTRUCTIONS

#### OPERATION

##### Operation with air:

The valve is provided with air connections with 1/8" BSP female thread.

Air connections that are not in use must be fitted with bleeding nipples.

Apply air to:

PI: to close valve

PII: to open valve

PIII: to hold the CIP poppet valves shut when the valve is open.

Note: PII & PIII air fittings are connected on a common circuit, so as the poppet valves will operate in conjunction with the main actuator.

##### Control unit

The 1.5" (025) to 4"(100) valves can be supplied with the PENTAIR AVID F783E or F784 control head, that mounts directly to the top of the actuator and incorporates position switches, pneumatic solenoid(s), local position indication LED's, and a choice of controller interfaces to suit most popular control systems, all in a single IP67 enclosure.

##### Position indication (option)

Standard 18 mm barrel type proximity sensors can be mounted using a bracket fitted within the sight-housing, and the target can be fitted to the plug shaft. Kits are available for specific valves/actuator sizes upon request. Note this solution is suitable for sizes 1.5" to 4" only.

##### Cleaning

The valve is suitable for CIP (Clean In Place) cleaning. If the valve is in the closed position, the cavity between both valve sealing rings may be cleaned by flushing one of the two CIP valves, the second must be vented to a drain. Both CIP valves must be in the open position.

When used on highly viscous or crystallising liquids, or if the times between valve cycles or cleaning are lengthy, a water flush through the leakage chamber between valve cycles is recommended to prevent build up or solidification of product within the drain galleries and tubing.

The valve material is resistant to detergents that are commonly used in the food industry, at a temperature of about 80°C. After cleaning the system should be rinsed with clean water to help inhibit corrosion from any chemical residues.

##### Service intervals

Sealing and wearing parts of the valve should be checked once a year. For special applications (such as highly viscous or crystallising liquids) the service interval should be adjusted based on individual experience with these products.

#### MAINTENANCE INSTRUCTIONS

##### Notes:

Use a medium strength thread lock compound eg. LOCTITE 243, on all screwed shaft joints. Lubricate all O-rings and bushes with an approved food grade lubricant before fitting.

##### IMPORTANT:

Keep fingers clear of moving parts when applying or removing air to the actuator.

##### Tools & equipment

Tools and equipment required for the maintenance of this valve are as follows:

- Appropriate sized open ended spanners: M10, M13, M16, M17, M22 & M24.
- Appropriate sized hex drive keys: M5, M6 (if required).
- Compressed air source, controlled via a small on/off valve, preferably with venting port (recommended).
- Medium strength thread lock e.g. LOCTITE 243.
- Food approved spray-on Silicone lubricant, and food grade grease. eg. MOLYKOTE 111.
- O-ring hook or similar tool (see Fig. 3).
- PENTAIR dovetail seal loading tool, hand type (see Fig. 4) or bench type (see Fig. 5).

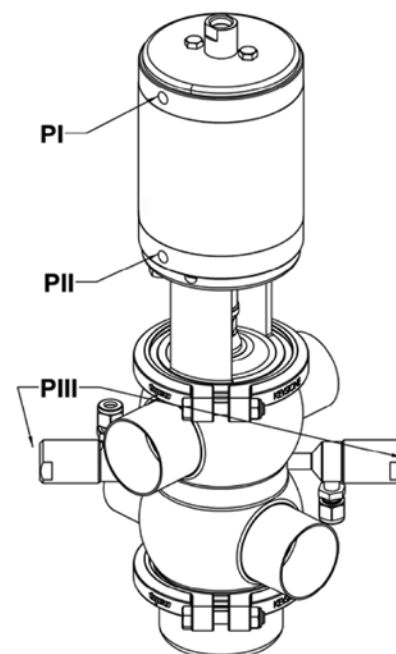

Figure 1

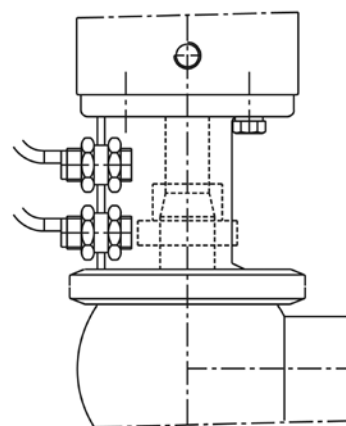

Figure 2  
Position indication (option)



Figure 3



Figure 4

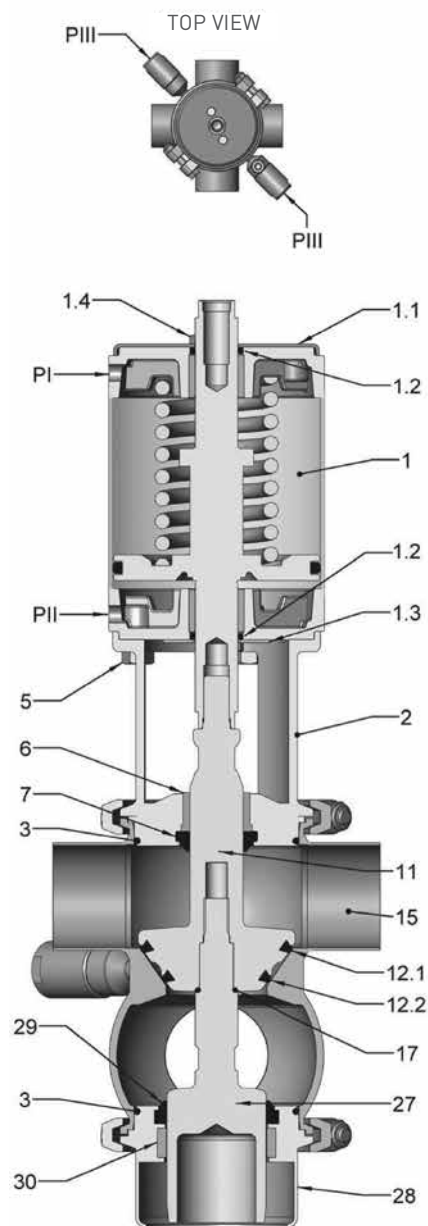

Figure 5

# PENTAIR DOUBLE SEAL VALVES

## F269B+ INSTALLATION AND OPERATING INSTRUCTIONS

### REPAIR AND MAINTENANCE INSTRUCTIONS



#### Parts list

Item No	Description	Material	Qty
1	F272S - actuator assembly	Various	1
1.1	Top cover	304S/S	1
• 1.2	O-ring end plates	NBR	2
1.3	O-ring retainer	304S/S	1
1.4	Hex head bolt M6x16	304S/S	4
2	Sight housing / product flange	304S/S	1
2.1	Sight housing	304S/S	1
2.2	Product flange	316LS/S	1
◇ 3	O-ring body	Various	2
5	Hex head bolt M8x16	304S/S	4
◇ 6	Wiper seal bush	PTFE	1
◇ 7	Wiper seal	Various	1
8	Hex head bolt M8x45	304S/S	4
9	Nyloc nut M8	304S/S	4
10	Clamp pair	304S/S	2
11	Plug	316LS/S	1
◇ 12.1	Dovetail seal (upper)	Various	1
◇ 12.2	Dovetail seal (lower)	Various	1
15	Body F269B (butt weld)	316LS/S	1
18	Ferrule front	304S/S	2
19	Ferrule back	304S/S	2
20	Ferrule nut	304S/S	2
°◇ 21	O-ring - CIP piston	FPM	2
22	Spring - CIP valve	302S/S	2
23	CIP valve piston	PTFE	2
°◇ 24	O-ring - CIP piston	NBR	2
25	CIP valve housing	316LS/S	2
26	O-ring plug	Various	1
27	Balancer	316LS/S	1
28.1	Bottom cover balance	316LS/S	1
28.2	Balance protector	316LS/S	1
29	Wiper seal	Various	1
30	Balance guide ring	316LS/S	1

#### Seal kits

•	Actuator seal kit	Various	1
°	CIP seal kit	Various	1
◇	Wet end seal kit	EPDM	1
		NBR	1
		FPM	1

3A compliance - To maintain 3A compliance only use genuine PENTAIR spare parts

#### Disassembly instructions (refer to diagram on page 3)

- Remove, if present, any indicators or control units.
- For spring-to-close valves: supply pressurised air to P II to lift spring load off seat (see over page).
- Loosen and remove the upper clamp set.
- Vent all air pressure from actuator, returning plug will lift actuator assembly slightly.
- For spring-to-open valves: Vent all air pressure from actuator.
- Disconnect all air tubes.
- Pull actuator assembly (1), together with valve plug (11), from the body, take care to avoid damage to the seal surfaces.
- Loosen and remove the plug (11), from actuator assembly, use flats on actuator shaft and on plug stem.

Note: If LOCTITE does not release use a small amount of heat on joint.

If servicing the actuator seals:

- Loosen and remove O-ring retaining plate bolts (1.4) and remove plates (1.1 & 1.3)
- Sight housing/product flange sub-assembly (2), can be removed to assist if necessary.
- Extract the shaft O-rings (1.3) using hook tool [Fig. 3].

If servicing CIP poppet valves:

- Remove CIP valve housings using M24 flats on end and withdraw all the components.

# PENTAIR DOUBLE SEAL VALVES

## F269B+ INSTALLATION AND OPERATING INSTRUCTIONS

### REPAIR AND MAINTENANCE INSTRUCTIONS

#### Replacing the Dovetail Seals

##### Notes:

- 1) Recommended tool for seal replacement is a PENTAIR seal loading tool (see tools above).
  - 2) A small amount of Silicon spray around the groove and seal can assist in the seal loading process.
- First pry out of their grooves any seals to be replaced by piercing in the centre of the seal with the sharp end of the o-ring hook and levering outwards. Take care not to slip and injure yourself during this process and not to damage the edges of the seal grooves. The seals will be destroyed during this stage.
  - Take the seal to be fitted and sit it on the tapered end of the plug.
  - Place a thumb on the top of the seal and push the top lip of the smallest diameter of the seal into the groove.
  - Stretch the remainder of the seal in a circular direction until the entire top lip is inside the groove.
  - Now using the PENTAIR loading tool, begin by folding one small area of the remaining outside lip in the groove.
  - Carry on the same operation directly opposite the first point and continue as indicated.
  - Once the seal is fully loaded check that it is protruding uniformly around its entire circumference. If the seal appears spongy in places, this indicates air entrapment. This can be re-leased by forcing the tip of the PENTAIR loading tool down the side of the seal in the affected area, to vent any trapped air.

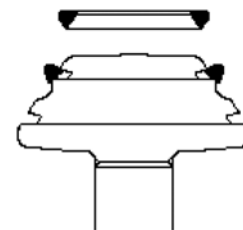

Figure 6

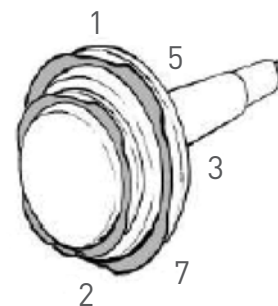

Figure 7

#### Assembly instructions [refer to diagram on page 3]

- First fit the new O-rings (1.2) into their respective grooves.
- Now fit the O-ring retaining plates (1.1 & 1.3) If a control head is to be fitted (1.1) is replaced with an O-ring retaining bush, which is supplied with each new actuator or complete valve assembly (can also be purchased separately).
- If the sight housing (2) was removed earlier replace this now, using a small amount of thread lock on all screws.
- Replace stem seal bush (6) only if it shows signs of wear, and fit stem seal (7) if required.
- Apply thread lock compound onto the thread of the male shaft (11).
- Fit the male shaft thru the stem seal and into the end of the actuator cassette and tighten using shaft flats.
- Fit a new body seal O-ring (3) to the sight housing product flange, and lightly lube outside edges.

#### Assembly of the CIP poppet valves

- Fit the two O-rings to the CIP poppet pistons. Lightly smear the O-rings with food grade grease.
- Place the spring over the piston and insert the assembly into the poppet valve body.
- Screw the CIP valve housing over the CIP poppet piston and onto the valve body, tighten securely. Refit any air fittings.

#### Assembly of the Main Valve

- Refit the actuator control head if fitted, and install all air lines.
- For Spring-to-Close valves: supply regulated air to P II of the actuator to retract the plug.
- For Spring-to-Close valves: remove air supply from P II of the actuator to allow plug to retract.
- Guide the plug assembly into the valve body, taking care not to damage the sealing surfaces and align and engage the body seal fully.
- Install the upper clamp set and tighten.
- Stroke the valve using the manual controls to check the position indicator switches are working correctly.

##### Notes:

- 1) Recommended tool for actuator seal replacement is an O-ring hook (see Fig. 3).
- 2) Spray a small amount of Silicon spray on all the O-rings before fitting. Lubricate bushes with a light smear of a food grade grease such as MOLYKOTE 111.
- 3) All shaft joints to be secured using a medium strength thread lock compound, such as LOCTITE 243

# PENTAIR DOUBLE SEAL VALVES

## F269J+ INSTALLATION AND OPERATING INSTRUCTIONS

### REPAIR AND MAINTENANCE INSTRUCTIONS

---

#### Troubleshooting guide

Valve closes with great force  
Valve closes in the flow direction.  
Install the valve so it closes against flow direction.

Leakage along stem of plug 11  
Check stem seal 7.

Leakage along balancer 27  
Check balancer seal 29.

Leakage at clamp joints  
Check O-rings 3.

Leakage from CIP valves when main valve open  
Check O-ring 21 and sealing face of CIP valve piston 23.

Leakage from CIP valves when main valve closed  
Check Plug seals 12.1 and 12.2  
Check liquid pressure on bottom pipe.

Air leakage in actuator assembly.  
Check O-rings 1.2

Air leakage via CIP valves  
Check O-rings 24

Valve opens/closes slowly  
Air supply pressure is below 4 bar. Air tube is too long, is pinched, or the diameter is too small.  
Liquid in the actuator.

Valve opens/closes with irregular movement  
Check if there is liquid in the actuator.

Liquid in actuator  
Drain and place a water separator in the air supply.

#### Technical specifications

##### Valve material

All metal parts that come into contact with the liquid are made of stainless steel according to W.Nr. 1.4404. (AISI 316L)

The parts that do not come into contact with the liquid are made of stainless steel W.Nr. 1.4301 (AISI 304) or appropriate polymer. The actuator bearings are made of bronze alloy.

##### Gasket material

The O-rings and seals that come into contact with the liquid are made of FDA and 3A compliant EPDM, NBR (Nitrile) or FPM (Viton). The stem seal is made of SANTOPRENE, EPDM, NBR or FPM.

##### Air supply pressure

The air supply pressure must be between 4 and 8 bar. We recommend dry air of 6 bar.

##### Air consumption

The air consumption in nl. (normal litres) per stroke is given in the table below. The consumption is calculated for a single acting actuator.

# PENTAIR DOUBLE SEAL VALVES

## F269J+ INSTALLATION AND OPERATING INSTRUCTIONS

### REPAIR AND MAINTENANCE INSTRUCTIONS

#### Air pressure

	Valve sizes			
	025	040-050	065-080	100
4 bar	0.9	1.2	3.2	4.6
6 bar	1.2	1.7	4.5	6.4
8 bar	1.5	2.1	5.6	8.2

#### Valve body porting options

Type 11

Type 12

Type 21

Type 22

EXAMPLE

21 90-0018



**PENTAIR FLOW CONTROL PACIFIC PTY LTD**

12-14 KAIMIRO STREET, PUKETE INDUSTRIAL ESTATE, HAMILTON, 3200, NEW ZEALAND [PACIFICNZHYGIENICSALES@PENTAIR.COM](mailto:PACIFICNZHYGIENICSALES@PENTAIR.COM) [WWW.PENTAIR.COM](http://WWW.PENTAIR.COM)

All Pentair trademarks and logos are owned by Pentair. All other brand or product names are trademarks or registered marks of their respective owners.

Because we are continuously improving our products and services, Pentair reserves the right to change specifications without prior notice. Pentair is an equal opportunity employer.

PHOBE-0059 E-14/16 © 2016 Pentair - All Rights Reserved.